

Multiprotocol Switched Services (MSS)
Server Module

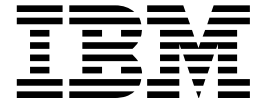

Installation and Initial Configuration Guide

Multiprotocol Switched Services (MSS)
Server Module



Installation and Initial Configuration Guide

Note

Before using this information and the product it supports, be sure to read the general information under Appendix B, "Notices."

Second Edition (October 1997)

This edition applies to Version 2.0 of the Multiprotocol Switched Services (MSS) Server Module.

Order publications through your IBM representative or the IBM branch office serving your locality. Publications are not stocked at the address given below.

A form for readers' comments appears at the back of this publication. If the form has been removed, address your comments to:

Department CGF
Design & Information Development
IBM Corporation
PO Box 12195
RESEARCH TRIANGLE PARK NC 27709
USA

When you send information to IBM, you grant IBM a nonexclusive right to use or distribute the information in any way it believes appropriate without incurring any obligation to you.

© **Copyright International Business Machines Corporation 1996, 1997. All rights reserved.**

Note to U.S. Government Users — Documentation related to restricted rights — Use, duplication or disclosure is subject to restrictions set forth in GSA ADP Schedule Contract with IBM Corp.

Contents

About This Guide	v
Who Should Use This Guide	v
How To Proceed	v
MSS Server Library Overview	vi
Accessing the MSS Server Softcover Library	vii
Visit Our Web Sites	viii
Information Updates and Corrections	viii
Latest Switch Driver Images	viii
Online Support	viii
Summary of Changes	viii
Chapter 1. Installing the A-MSS Server Module	1-1
Chapter 2. Problem Solving	2-1
Chapter 3. Accessing the A-MSS Server Module	3-1
Methods of Connecting	3-1
Teletype (TTY) Connection	3-1
SLIP Connection	3-3
Ethernet Connection	3-4
ATM Network Connection	3-4
Chapter 4. Performing Initial Configuration of the A-MSS Server Module	4-1
When to Use the Default Configuration	4-1
When to Perform an Initial Configuration	4-3
Performing an Initial (Quick) Configuration	4-3
Full Configuration	4-5
Appendix A. Common Tasks	A-1
Appendix B. Notices	B-1
Electronic Emission Notices	B-1
Trademarks	B-3
Appendix C. Safety Information	C-1
Index	X-1

Figures

3-1. Local Serial Connection to the EIA 232 Port	3-2
3-2. Remote Serial Connection to the PCMCIA Modem (Voice/Data/Fax PCMCIA Modem or Data/Fax PCMCIA Modem)	3-2
3-3. Connection Using IP through the Ethernet Port	3-4
3-4. Connection Using IP Over the ATM Network (shown with the 8210)	3-4

About This Guide

This guide explains how to set up the Multiprotocol Switched Services (MSS) Server Module, perform the initial configuration, and identify and correct some problems that might occur during installation.

Who Should Use This Guide

This guide is intended for the person responsible for installing the A-MSS Server Module. It is assumed that this person is familiar with installation and cabling charts.

How To Proceed

The following steps describe how to install your MSS Server. You should document all of the network information that will be required to install, connect, and configure the MSS Server.

Installation

- **1** Install the MSS Server. Chapter 1, "Installing the A-MSS Server Module" describes the hardware installation procedure. (Alternatively, installation by IBM service personnel is available. Contact your IBM representative for additional information.)
- **2** Contact your network administrator to determine whether you can use the default configuration or whether you need to perform an initial configuration. If the network administrator wants to use the default configuration (see "When to Use the Default Configuration" on page 4-1), then the installation and initial configuration tasks are completed. Otherwise, you need to perform an initial configuration.

Initial Configuration

- **1** Access the A-MSS Server Module as described in Chapter 3, "Accessing the A-MSS Server Module."
- **2** Perform the initial configuration as described in Chapter 4, "Performing Initial Configuration of the A-MSS Server Module."
- **3** Contact your network administrator to perform a full configuration, and refer to the *Multiprotocol Switched Services (MSS) Server Interface Configuration and Software User's Guide* and *Multiprotocol Switched Services (MSS) Configuring Protocols and Features* provided in softcopy with the MSS Server).

MSS Server Library Overview

Planning and Installation

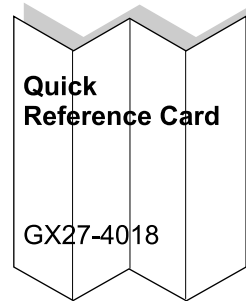
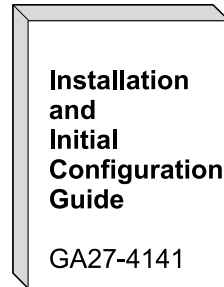
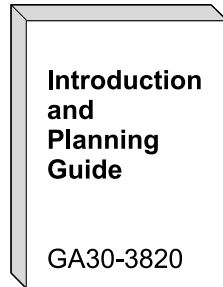

Configuration

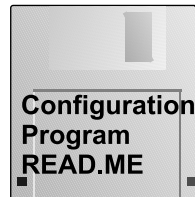
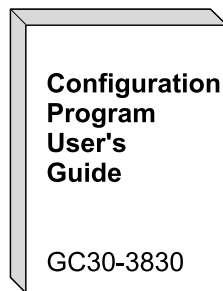

Diagnostics/Maintenance



Operations and Network Administration

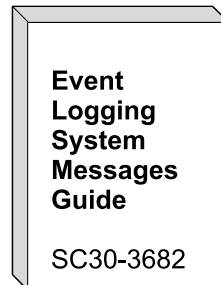
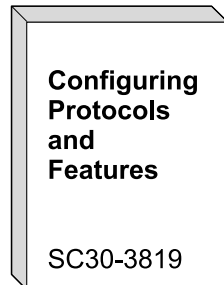
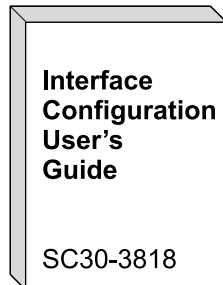

The following IBM hardcopy publications are shipped with the product. The manuals in this list are also included in displayable softcopy form on the Multiprotocol Switched Services (MSS) Softcopy Library CD-ROM (SK2T-0378). This CD-ROM is shipped with initial orders for the MSS Server.

The reference card and the safety information booklet are shipped in hardcopy only and are not included on the CD-ROM.

- *Multiprotocol Switched Services (MSS) Server Module Installation and Initial Configuration Guide*, GA27-4141
- *Multiprotocol Switched Services (MSS) Server Module Quick Reference Card*, GX27-4018
- *CAUTION: Safety Information - Read This First*, SD21-0030

The following publications are not shipped in hardcopy, but are provided in softcopy form on the Multiprotocol Switched Services (MSS) Softcopy Library CD-ROM. All of these manuals (with the exception of the *Event Logging System Messages Guide*) can be separately ordered in hardcopy form through your IBM marketing representative.

- *Multiprotocol Switched Services (MSS) Server Introduction and Planning Guide*, GC30-3820
- *Multiprotocol Switched Services (MSS) Server Service and Maintenance Manual*, GY27-0354
- *Multiprotocol Switched Services (MSS) Server Interface Configuration and Software User's Guide*, SC30-3818
- *Multiprotocol Switched Services (MSS) Configuring Protocols and Features*, SC30-3819
- *Configuration Program User's Guide for Nways Multiprotocol Access, Routing and Switched Services*, GC30-3830
- *Event Logging System Messages Guide*, SC30-3682

Accessing the MSS Server Softcover Library

Important: Whether you choose to read the softcopy MSS Server publications directly from the CD-ROM or to upload the individual books to your hard disk, you first must install the Library Reader program (contained on the CD-ROM) on your workstation to enable you to view the publications.

The *Multiprotocol Switched Services (MSS) Server Softcopy Library* (included with the CD-ROM) describes how to install the Library Reader and how to access the softcopy books from a personal computer or PS/2 computer running DOS, Windows, or OS/2.

For alternative methods of managing your softcopy books, see the *Online Reference Online Library* that is on the CD-ROM.

Visit Our Web Sites

You can obtain the latest information on and support for the MSS Server by visiting our Web sites.

Information Updates and Corrections

To keep informed of engineering changes, clarifications, and fixes that are implemented after the manuals have been printed, refer to the IBM MSS Server home page at:

<http://www.networking.ibm.com/820/820prod.html>

Latest Switch Driver Images

To access updated versions of the MSS Server switch driver images, refer to the IBM Switch Driver Images page at:

<http://www.networking.ibm.com/nes/nesswitc.htm>

Online Support

To obtain support information and code for the MSS Server, refer to the IBM Network Environment Support page at:

<http://www.networking.ibm.com/nes/>

Summary of Changes

This manual has been revised to include the following changes and enhancements:

- Repackaging of the A-MSS Server Module to a one-slot 8260 module
- 166-MHz 603ev PowerPC processor for the A-MSS Server Module
- Addition of a 10BASE-T Ethernet service port to the A-MSS Server Module
- Replacement of the A-MSS Server Module's PCMCIA hard drive with an internal integrated drive electronics (IDE) hard disk
- Addition of an optional 20-MB flash drive for the A-MSS Server Module
- 64 MB of DRAM for both the 8210 and the A-MSS Server Module
- Extensions to the Next-Hop Routing Protocol (NHRP), allowing workstations and servers to make routing decisions (Zero-Hop Routing)
- Support for APPN, including dependent logical unit requester (DLUR), boundary access node (BAN), boundary network node (BNN), and high-performance routing (HPR) for both LAN emulation and native ATM support
- Ability to receive and transmit encapsulated bridge frames natively over ATM switched virtual circuits (SVCs)
- Support for Banyan VINES

The technical changes and additions are indicated by a vertical line (|) to the left of the change.

Chapter 1. Installing the A-MSS Server Module

These instructions explain how to install the A-MSS Server Module in the 8260 Nways Multiprotocol Switching Hub or the 8265 Nways ATM Switch. If you have any problems during setup, refer to Chapter 2, "Problem Solving."

1. Verify contents

Verify that the following items are included with your A-MSS Server Module:

Hardware

- PCMCIA modem and cable (in many countries)
- PCMCIA 20-MB flash drive (optional)

Documentation

In addition to this document, the package should include:

- *CAUTION: Safety Information—Read Me First*, SD21-0030
- *IBM MSS Server Module Reference Card*, GX27-4018
- *IBM Multiprotocol Switched Services Softcopy Library CD-ROM*, SK2T-0378

Software

- Configuration Tool Program package (contains diskettes and information)
- Minimum A-CPSW code level **V2.5.2** is required to support the A-MSS Server Module.

2. Carefully remove module from antistatic bag

- A. Remove the module, in its antistatic bag, from the shipping carton.

Electrostatic discharge (ESD) can damage the static-sensitive devices on circuit boards. To avoid this kind of damage, use the following precautions:

- Do not remove the board from its antistatic shielding bag until you are ready to insert it into the hub.
- Use correct grounding techniques when inspecting and installing module. Use a foot strap and grounding mat, wear a grounded static discharge wrist strap, or touch a grounded rack or other source of ground before you handle the module.

- B. Remove the module from the antistatic bag. Inspect it for damage. Always handle the module by the faceplate; do not touch the components. If the module appears to be damaged, replace it in the antistatic bag and contact your local supplier.

3. Front panel

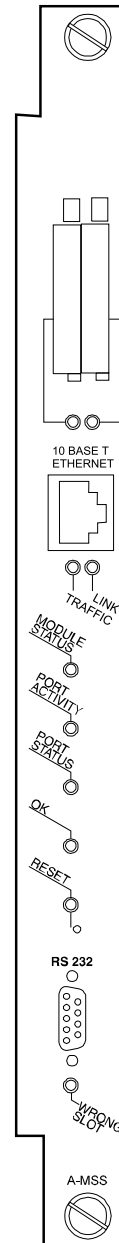

4. Install PCMCIA device

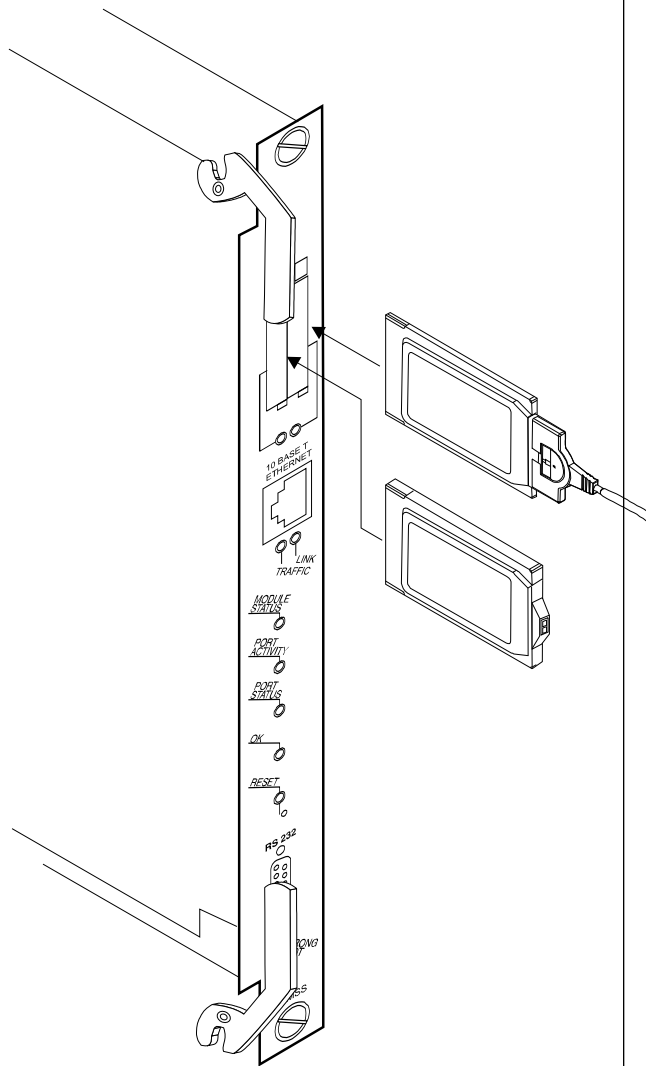

Note: Correct installation according to these instructions is a condition for compliance with the regulations of electromagnetic interference (see “Electronic Emission Notices” on page B-1 for additional information).

Install the PCMCIA modem, top side facing left, in the right PCMCIA slot and attach its modem cable. Verify that it is correctly seated in the slot and that the cable is correctly attached.

Install the PCMCIA flash drive in the left PCMCIA slot.

5. Insert module in hub

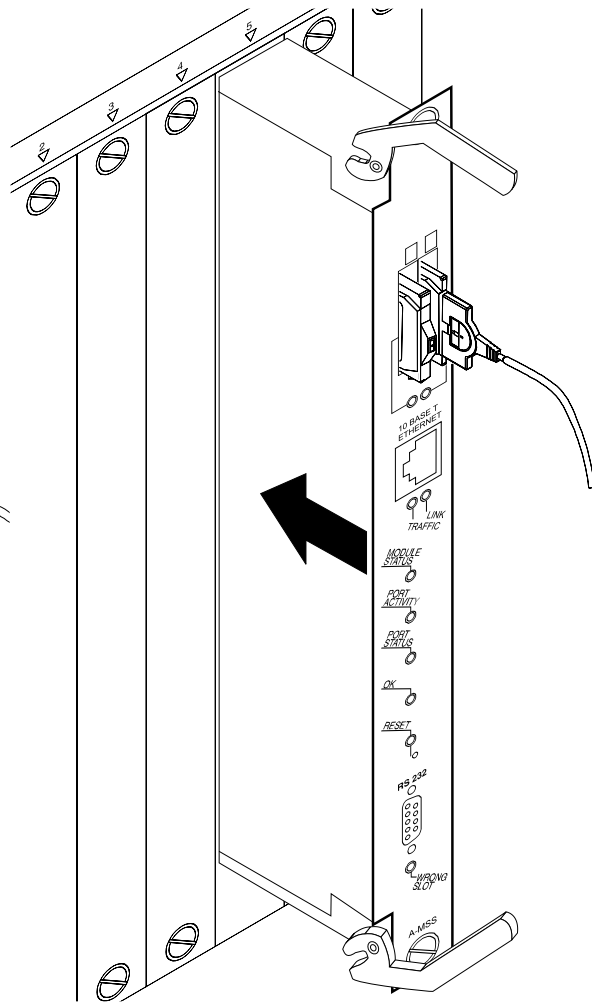

Installing the module does not require you to power down the hub. You can hot-swap the module like other 8260 or 8265 modules, that is, you can insert the module into the appropriate slot and remove it while the hub is operating.

Grasp the module by the top and bottom of the faceplate, carefully insert the module into its slot, and guide it straight while pressing evenly and firmly to correctly seat the module connectors into the hub backplane.

When it is completely seated, close the latches and tighten the thumb-screws to secure the module.

7. Verify module LEDs

Several minutes after reset, verify the following LED conditions:

- If there is traffic flowing across the Ethernet network, the TRAFFIC LED will be ON (Green).
- If the Ethernet port is connected, the LINK LED should be ON (Green).
- The MODULE STATUS LED should be ON (Green).
- The PORT ACTIVITY LED comes on when there is activity on the port. If there is traffic flowing to the A-MSS Server Module, the PORT ACTIVITY LED will be ON (Yellow).
- The PORT STATUS LED should be ON (Green).
- The OK LED should be ON (Green).
- The RESET LED should be OFF.
- The WRONG SLOT LED should be OFF.

See Chapter 2, "Problem Solving" if the LEDs are not lighted as described.

Hardware installation is complete.

8. Contact Network Administrator

Inform your network administrator that you have installed the module and it is operating correctly, and provide him with the telephone number of the modem in your module.

After installation, the A-MSS Server Module must be configured to be fully operational. The module is shipped with a default configuration that allows it to be configured remotely as described in "When to Use the Default Configuration" on page 4-1.

In most cases, your network administrator will not want to use this default configuration when he performs the (full) configuration. Instead, he will want you first to set up a local configuration console (see Chapter 3, "Accessing the A-MSS Server Module"), and perform an initial (quick) configuration (see Chapter 4, "Performing Initial Configuration of the A-MSS Server Module").

Inform your network administrator when you are finished so that he can perform the full configuration.

Chapter 2. Problem Solving

To identify and correct any problems that occur during setup, see the following chart.

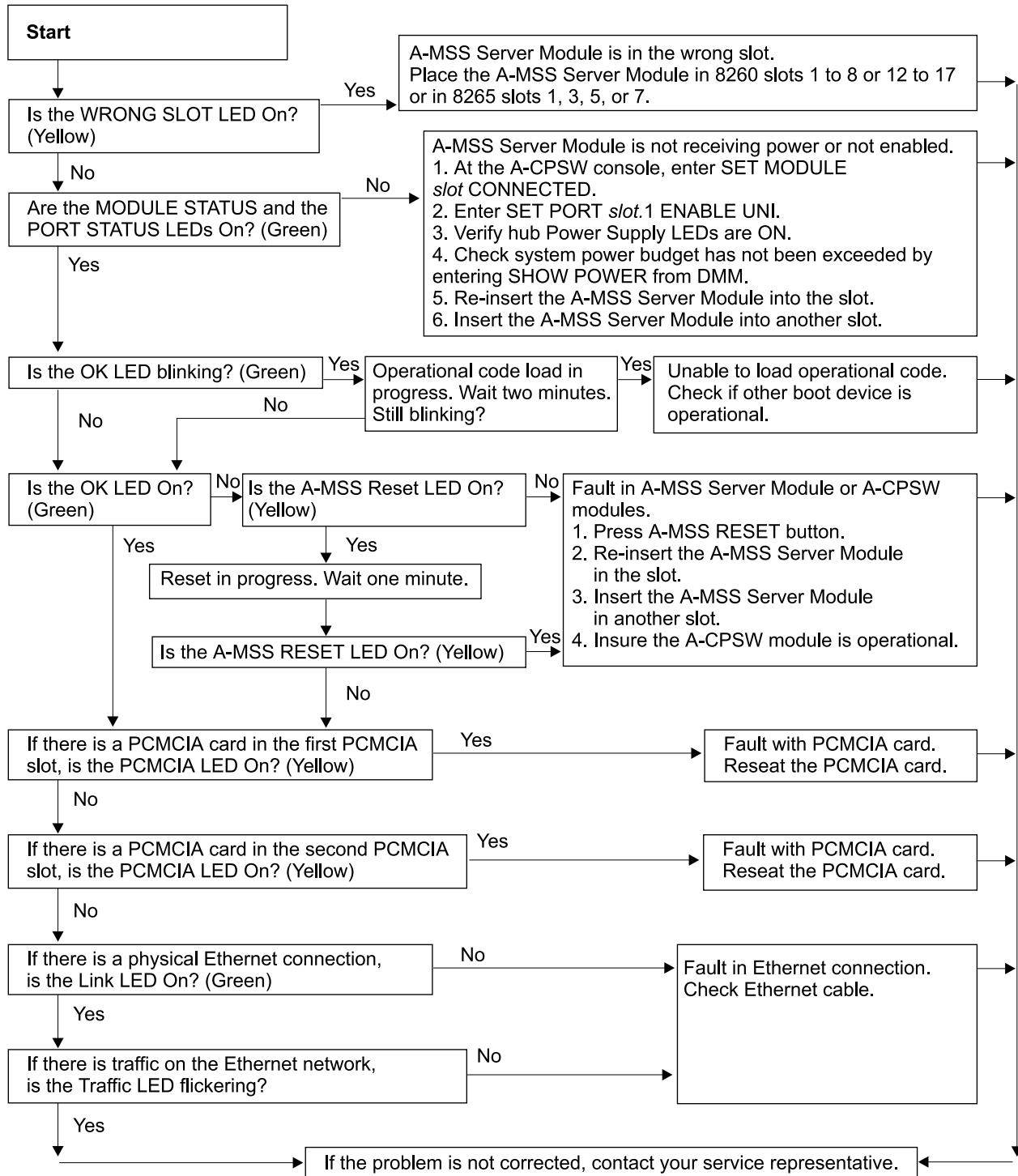

Chapter 3. Accessing the A-MSS Server Module

This chapter describes the methods supported for accessing the A-MSS Server Module.

Methods of Connecting

You have four methods of connecting to the MSS Server:

- Using a teletype (TTY) connection
- Using a serial line IP (SLIP) connection
- Using an Ethernet connection
- Using the ATM network

TTY, SLIP, and Ethernet are considered *out-of-band* connections. Out-of-band connectivity is usually employed when the ATM network is not operational, or the MSS Server has not been configured yet. Therefore, if you are performing an initial (quick) configuration, you should use an out-of-band method (usually TTY).

The connection via the ATM network is *in-band*. In-band connectivity requires IP connectivity over the MSS Server's ATM network attachment. To enable in-band IP connectivity, you must configure one of the following on your workstation:

- LIS client or server (for Classical IP)
- LE client to which an IP address has been assigned (for LAN emulation)
- IP host services

Note: The MSS Server is shipped with a default configuration that allows in-band access to the MSS Server from a workstation running Classical IP. Use caution when installing the MSS Server in your network with the default configuration. See "When to Use the Default Configuration" on page 4-1 for more information about the default configuration.

The in-band and out-of-band connectivity will be detailed in the following sections.

Teletype (TTY) Connection

For this method you have three alternatives:

- A local connection through a null modem cable attached to the EIA 232 service port (see Figure 3-1 on page 3-2)
- A remote connection through a modem attached to the EIA 232 service port
- A remote connection through the PCMCIA modem, the Voice/Data/Fax PCMCIA Modem, or the Data/Fax PCMCIA Modem (see Figure 3-2 on page 3-2)

You can set up both remote and local connections, but only one connection can be active at any given time. For example, if a workstation is connected locally to the EIA 232 service port and a call comes in over the Voice/Data/Fax PCMCIA Modem or the Data/Fax PCMCIA Modem, priority is given to the call. After the call, the workstation will have to log back into the A-MSS Server Module.

Either connection, local or remote, must be made using communications software that enables terminal emulation and file transfer. You can continue to use local or remote access to the A-MSS Server Module after it has been configured.

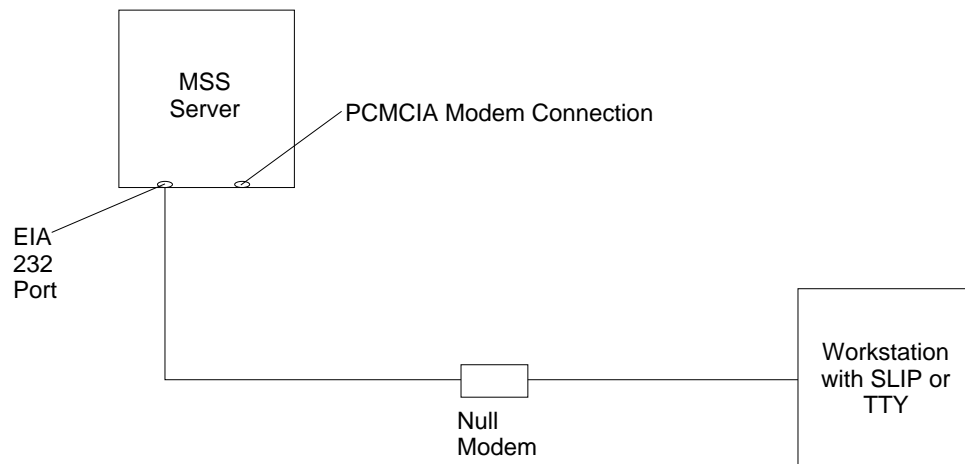

Figure 3-1. Local Serial Connection to the EIA 232 Port

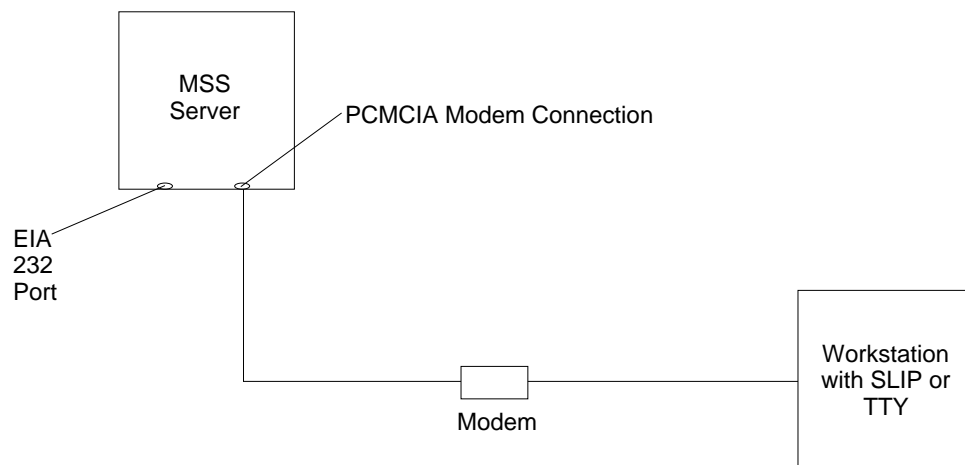

Figure 3-2. Remote Serial Connection to the PCMCIA Modem (Voice/Data/Fax PCMCIA Modem or Data/Fax PCMCIA Modem)

Local and Remote Console Access

When accessing the MSS Server locally on a null modem cable attached to the EIA 232 service port or remotely through the PCMCIA modem, use VT100 terminal emulation. Because VT100 does not define function keys above F4, edit the keyboard mapping for your terminal emulation as follows: For key definition F6, enter the mapping (ESC)OU. For key definition F9, enter the mapping (ESC)(Left square bracket)009q.

Note: (ESC) represents the carat symbol followed by the left square bracket.

Default Settings for Serial Port

These are the default settings for the serial port:

Speed 19.2 Kbps
Parity None
Data Bits 8
Stop Bits 1

Once the MSS Server operational code has loaded, the line speed for the serial port is automatically set to 19.2 Kbps.

Default Settings for PCMCIA Modem

The PCMCIA modem is a 28.8 Kbps V.32 bis modem. It is set up with a default speed of auto detect.

These are the default settings for PCMCIA modem:

Speed Auto detect
Parity None
Data Bits 8
Stop Bits 1

SLIP Connection

Over the local or remote connection described on page 3-1, you can choose to use the SLIP protocol instead of the TTY connection. Using SLIP requires TCP/IP on the workstation that connects to the MSS Server.

To configure SLIP, use these addresses:

The default SLIP address of A-MSS Server Module
10.1.1.2

The default IP address of the workstation
10.1.1.3

For instructions about installing SLIP, refer to the documentation for your version of TCP/IP.

Note: A PING done on the PCMCIA modem may take up to 2 minutes.

Ethernet Connection

Through a 10BASE-T Ethernet cable attached to the Ethernet service port, you can use Telnet (see Figure 3-3). Using Telnet requires TCP/IP on the workstation that connects to the MSS Server.

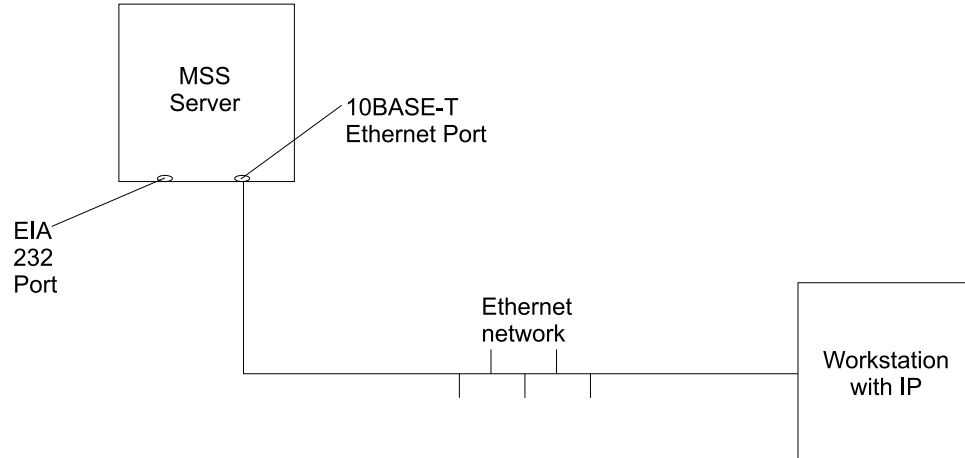

Figure 3-3. Connection Using IP through the Ethernet Port

To use Telnet over the Ethernet connection, use these addresses:

The default IP address of the A-MSS Server Module

10.1.2.2

The default IP address of the workstation and gateway

10.1.2.3

The default subnet mask of the A-MSS Server Module

255.255.255.0

For instructions about using Telnet over Ethernet, refer to the documentation for your version of TCP/IP.

ATM Network Connection

Figure 3-4 shows an *in-band* connection over the ATM network.

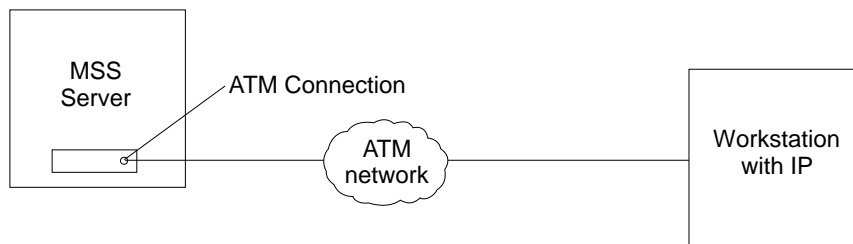

Figure 3-4. Connection Using IP Over the ATM Network (shown with the 8210). The 8210 or the module must be operational in the network to use this connection.

You can access the MSS Server via the ATM network only after it has been configured fully or by using the default configuration. Therefore, for an initial (quick) configuration, you usually use one of the three connection methods described in the

| previous three sections. See Chapter 4, “Performing Initial Configuration of the
| A-MSS Server Module” for more information on initial configuration.

| After you have completed the initial configuration, you have to reload the MSS
| Server to activate the configuration. After this reload, the MSS Server is
| operational in the network, and you can access it via a LAN emulation or a
| Classical IP client.

Chapter 4. Performing Initial Configuration of the A-MSS Server Module

This chapter describes the default configuration, when and how to perform an initial (quick) configuration to enable the MSS Server to communicate with the network, and discusses full configuration of the MSS Server.

When to Use the Default Configuration

The A-MSS Server Module is shipped with a default configuration that allows it to be configured remotely from a Classical IP workstation in the network using the Configuration Program via Telnet, the command line interface via Telnet, or the Web browser interface.

Notes:

1. The default configuration is not intended for normal operation.
2. Use caution when installing the MSS Server in your network with the default configuration. If the default configuration conflicts with other devices in your network (such as using the IP or ATM address of another device), you must use one of the out-of-band connection methods described in "Methods of Connecting" on page 3-1.
3. Connect and configure MSS Servers using the default configuration one at a time. Conflicts arise if more than one MSS Server, using the default configuration, is connected to the network at the same time.

Default Configuration Parameters

The following sections list the default configuration parameters.

Signaling Protocol

Parameter	Value
ATM	UNI 3.0

IP Configuration - Classical IP

Parameter	Value
Interface	0
Type	ATM
Slot	1
Port	1
IP Address	10.1.0.1
IP Subnet Mask Address	255.255.255.0
ARP Server	Enabled
Refresh	5 minutes
Auto-refresh	Enabled
ESI	Universally administered address
Selector	00
Maximum SDU Size	9188

Note: The ESI and selector are for both a Classical IP server and client that are enabled in the default MSS Server configuration. These values are required when configuring a Classical IP workstation to use the MSS Server as its ARP server.

Emulated LAN Configuration - Token Ring

Parameter	Value
Name	TRelan1
Device	0
LES/BUS ESI	400082100001
LES/BUS Selector	04
Policies (Name)	TRelan1
Policies (Type)	Token Ring

LEC Interfaces - Token Ring

Parameter	Value
Interface	1
MAC Address	400082100001
Name	TRelan1
Type	Token Ring
Device	0
ESI	400082100001
Selector	02

IP Configuration - Token-Ring LAN Emulation

Parameter	Value
Interface	1
LEC	TRelan1
IP Address	10.1.1.1
IP Subnet Mask	255.255.255.0

Emulated LAN Configuration - Ethernet

Parameter	Value
Name	ETHelan1
Device	0
LES/BUS ESI	400082100002
LES/BUS Selector	04
Policies (Name)	ETHelan1
Policies (Type)	Ethernet

LEC Interfaces - Ethernet

Parameter	Value
Interface	2
MAC Address	400082100002
Name	ETHelan1
Type	Ethernet
Device	0
ESI	400082100002
Selector	02

IP Configuration - Ethernet LAN Emulation

Parameter	Value
Interface	2
LEC	ETHelan1
IP Address	10.1.2.1
IP Subnet Mask	255.255.255.0

SNMP Communities

Parameter	Value
Name	Public
Access Type	Read/write

When to Perform an Initial Configuration

If you have a new A-MSS Server Module and do not want to use the default configuration, if you have cleared the A-MSS Server Module's configuration, or if you have encountered a problem that cleared the configuration, you must perform the steps in "Performing an Initial (Quick) Configuration" before the A-MSS Server Module can be operational in the network.

Note: The Quick Configuration program assumes many defaults, some of which may not be appropriate for your installation. It is therefore advisable to use Quick Configuration to create only a partial configuration, to restart the MSS Server by entering the **restart** command, and then to configure the MSS Server fully from a TCP/IP station using one of the other configuration methods (the command line interface, the Configuration Program, or the Web browser).

Performing an Initial (Quick) Configuration

Before starting the Quick Configuration process, read these notes:

- Information shown in brackets, [], is the default. To use the default, press **Enter**. To use a value other than the default, choose from the values in the parentheses. If no value appears in the brackets, there is no default and you must type a value.
- To start or restart Quick Configuration from the Config> or Config (only)> prompt, type **qc** and press **Enter**.
- To return to the beginning of the current Quick Configuration section at any time, type **r**. For example, if you are in the Bridging Configuration section, type **r** and press **Enter** to return to the beginning of that section.
- To exit Quick Configuration, type **q** and press **Enter**. The Config> prompt will appear. Type **qc** and press **Enter**.
- When you have completed your configuration, you must restart the MSS Server for the configuration to take effect. At the end of the Quick Configuration program, you are given that option.

To start the Quick Configuration process:

- 1** Access the A-MSS Server Module as described in Chapter 3, "Accessing the A-MSS Server Module." The A-MSS Server Module responds with the operator console (OPCON) prompt (*).
- 2** Access the MSS Server's firmware and configure the MSS Server's interface number:
 - Enter **talk 6** at the * prompt.
 - Enter **add dev atm** at the Config > prompt.

```
* talk 6
Config>
Config> add dev atm
Device Slot #(0-1) [0]?
Adding CHARM ATM device in slot 0 port 0 as interface #0
Use "net 0" to configure CHARM ATM parameter
Config>
```

- 3** Configure the ATM address by entering the **net** command. The ATM address should be provided by your network administrator.

```
Config> net 0
ATM user configuration
ATM Config>
```

- 4** Start the Quick Configuration program to configure interfaces and bridging and routing protocols by entering **qconfig** or simply **qc** from the Config> prompt.

```
Config> qc
```

The Quick Configuration program presents a series of panels.

5 Configure Bridging:

- a** Answer **Yes** to the Configure Interfaces question.
- b** Supply the interface information required for the LAN interface that will communicate with the configuration program.
- c** Answer **No** to the Configure Bridging question.

6 Configure Protocols:

Answer **Yes** to the Configure Protocols question.

7 Configure IP:

- a** Answer **Yes** to the Configure IP question.
- b** Answer **Yes** to the Configure IP on this interface question for the LAN interface that will communicate with the configuration program.
- c** Enter the IP address at the *IP Address* prompt.
- d** Enter the IP mask at the *Address Mask* prompt.
- e** Answer **No** to the Configure IP on this interface question for the other A-MSS Server Module interfaces.
- f** Answer **No** to the Enable Dynamic Routing question.
- g** Answer **Yes** to the Save this configuration question.

8 Configure IPX, Booting, and Console Modem-Control:

- a** Answer **No** to the Configure IPX question.
- b** Answer **No** to the Configure Booting question.

C Answer **No** to the Configure Console Modem-Control question.

9 Restart the A-MSS Server Module:

Answer **Yes** to the Restart the A-MSS Server Module question.

10 Configure SNMP after the A-MSS Server Module reloads:

a Enter **talk 6** at the * prompt.

b Enter **protocols snmp** at the Config > prompt.

c Define a public community with a read write trap as in the following example:

```
SNMP Config> set community access write my_community
```

d Exit SNMP configuration.

11 Exit the Quick Configuration program.

12 Enter **reload** to restart the A-MSS Server Module.

When the A-MSS Server Module completes the restart sequence, it can communicate with the configuration program.

13 Save the configuration.

Attention: After you have configured the MSS Server and it is operational, **always** back up the active configuration file. Keeping this file enables you to re-establish the MSS Server on the network should the active configuration become corrupted.

You can back up the active configuration file by retrieving it and storing it in the workstation.

14 Notify the network administrator that the initial configuration has been completed.

Full Configuration

The initial configuration procedure you have just performed will enable you to access the A-MSS Server Module over the network. The network administrator can now perform a full configuration of the module using any of these methods:

- Configuration Program
- Web browser HTML interface
- Command line interface (OPCON)

However, the Configuration Program is the preferred configuration method for these reasons:

- It can enable you to keep a number of copies of configuration files on a server for uploading to the appropriate A-MSS Server Modules.
- It does not alter any configuration parameters dynamically. This feature helps you control changes to the A-MSS Server Module configurations.

- It performs more input validation and cross-checking of the configuration parameters than the other methods.

The command line interface and the Web browser interface cause certain parameters to be altered dynamically. The binary files that they create are saved on the A-MSS Server Module, not in the workstation. These characteristics make them more difficult to use for managing the configuration of the A-MSS Server Module. However, they can be used to monitor the operations of the A-MSS Server Module, whereas the Configuration Program cannot. They are also useful when you want to change one of the parameters that can be dynamically altered.

For the information needed to complete the configuration, refer to the *Configuration Program User's Guide*, the *Multiprotocol Switched Services (MSS) Server Interface Configuration and Software User's Guide*, and the *Multiprotocol Switched Services (MSS) Configuring Protocols and Features*.

Appendix A. Common Tasks

This appendix provides a series of questions and answers dealing with common MSS Server installation, operation, and maintenance tasks, with suggestions as to where to find further help in performing them.

Command Line Interface

Question: How do I access the command line interface (the operating code)?

Answer: From within the firmware menu system (the System Management Services panel): press **F9**. The * prompt is displayed after the system boots.

The command line interface is described in the *Multiprotocol Switched Services (MSS) Server Interface Configuration and Software User's Guide*.

Displaying a List of Active Hardware Interfaces

Question: How do I display a list of active hardware interfaces?

Answer:

- 1 Access the command line interface (the * prompt).
- 2 Type **talk 6** and press **Enter** twice to reach the Config> prompt.
- 3 Enter **list dev**.
- 4 Press **Ctrl-p** to return to the command line interface.

Displaying the Operational State of the Interfaces

Question: How do I see the state (for example, up, down, disabled) of an interface?

Answer:

- 1 Access the command line interface (the * prompt).
- 2 Type **talk 5** and press **Enter** twice to reach the + (monitoring) prompt.
- 3 Enter **configuration**.
- 4 Press **Ctrl-p** to return to the command line interface.

Verifying Connectivity

Question: How do I verify that a given IP address is online?

Answer:

- 1 Access the command line interface (the * prompt).
- 2 Type **talk 5** and press **Enter** twice to reach the + prompt.
- 3 Type **protocol** and press **Enter**.
- 4 Type **ip** and press **Enter**. The prompt changes to IP>.

5 Type **ping** *IP address value* and press **Enter**. Press **Enter** to stop the ping process.

6 Type **exit** at the IP> prompt and press **Enter**. The prompt changes to +.

7 Press **Ctrl-p** to return to the command line interface.

Viewing Vital Software Data

Question: How do I view vital software data?

Answer:

1 At the * prompt, type **talk 6** and press **Enter** twice. The Config> prompt appears.

2 Enter **boot**.

3 Enter **describe**. The vital software data is displayed.

4 Press **Ctrl-p** to return to the command line interface.

Viewing Vital Hardware Data

Question: How do I view vital hardware data?

Answer:

1 Access the firmware main menu: During boot-up, press **F1** at the Prematurely terminate boot sequence prompt.

2 Select **4. Utilities**.

3 Select **9. View or Set Vital Product Data**.

4 Select **Hardware Vital Product Data**. The vital hardware data is displayed.

5 Return to the firmware main menu.

6 Press **F9** to load the operating software.

Running Quick Configuration

Question: How do I run the Quick Configuration program?

Answer: At the Config (only) prompt, enter **qc**.

Disabling the ATM Port

Question: How do I disable a configured ATM port?

Answer:

- 1 Access the command line interface (* prompt).
- 2 Type **talk 6** and press **Enter** twice to reach the Config> prompt.
- 3 Enter **list device**.
- 4 Make a note of the interface number of the port that you wish to disable.
- 5 Enter **disable interface** *interface number*.
- 6 Enter **write** to save your changes.
- 7 Reboot the MSS Server to make the configuration changes active.

For details of this procedure, refer to the *Multiprotocol Switched Services (MSS) Server Interface Configuration and Software User's Guide*.

Enabling the ATM Port

Question: How do I enable a configured ATM port that was disabled using **disable interface** (in "Disabling the ATM Port")?

Answer:

- 1 Access the command line interface (* prompt).
- 2 Type **talk 6** and press **Enter** twice to reach the Config> prompt.
- 3 Enter **list device**.
- 4 Make a note of the interface number of the port that you wish to enable.
- 5 Enter **enable interface** *interface number*.
- 6 Enter **write** to save your changes.
- 7 Reboot the MSS Server to make the configuration changes active.

For details of this procedure, refer to the *Multiprotocol Switched Services (MSS) Server Interface Configuration and Software User's Guide*.

Disabling the ATM Port to Suspend Traffic

Question: How do I disable a configured ATM port to suspend traffic?

Answer:

- 1 Access the command line interface (* prompt).
- 2 Type **talk 5** and press **Enter** twice to reach the + prompt.
- 3 Enter the **configuration** command.
- 4 Make a note of the interface number of the port that you want to disable.
- 5 Enter **disable** *interface number*.

Enabling the ATM Port to Resume Traffic

Question: How do I enable a configured ATM port (that was disabled using the **talk 5 disable** command in “Disabling the ATM Port to Suspend Traffic”) to resume traffic?

Answer:

- 1 Access the command line interface (* prompt).
- 2 Type **talk 5** and press **Enter** twice to reach the + prompt.
- 3 Enter the **configuration** command.
- 4 Make a note of the interface number of the port that you wish to enable.
- 5 Enter **test** *interface number*.

Note: If you use the **test** command to enable an interface that has been configured (in **talk 6**) as disabled, the next time that you reboot the MSS Server the interface will be disabled again.

Therefore, you should also use the **talk 6 enable interface** command to ensure that the interface is enabled the next time a reboot does occur.

For details of this procedure, refer to the *Multiprotocol Switched Services (MSS) Server Interface Configuration and Software User's Guide*.

Up-to-Date MSS Server Information

Question: How can I find out the most current information about the MSS Server?

Answer: Point your web browser to:

<http://www.networking.ibm.com/820/820prod.html>

Appendix B. Notices

References in this publication to IBM products, programs, or services do not imply that IBM intends to make these available in all countries in which IBM operates. Any reference to an IBM product, program, or service is not intended to state or imply that only IBM's product, program, or service may be used. Any functionally equivalent product, program, or service that does not infringe any of IBM's intellectual property rights may be used instead of the IBM product, program, or service. Evaluation and verification of operation in conjunction with other products, except those expressly designated by IBM, are the user's responsibility.

IBM may have patents or pending patent applications covering subject matter in this document. The furnishing of this document does not give you any license to these patents.

to the IBM Director of Licensing, IBM Corporation, 500 Columbus Avenue,
THORNWOOD NY 10594 USA.

Electronic Emission Notices

Federal Communications Commission (FCC) Statement

This equipment has been tested and found to comply with the limits for a Class A digital device, pursuant to Part 15 of the FCC Rules. These limits are designed to provide reasonable protection against harmful interference when the equipment is operated in a commercial environment. This equipment generates, uses, and can radiate radio frequency energy and, if not installed and used in accordance with the instruction manual, may cause harmful interference to radio communications. Operation of this equipment in a residential area is likely to cause harmful interference, in which case the user will be required to correct the interference at his own expense.

Properly shielded and grounded cables and connectors (IBM part number 55H8694 or its equivalent for the data/fax/voice modem, or IBM part number 72H4447 or equivalent for the data/fax modem) must be used in order to meet the FCC emissions limits. IBM is not responsible for any radio or television interference caused by using other than recommended cables and connectors or by unauthorized changes or modifications to this equipment. Unauthorized changes or modifications to this equipment may cause interference which could void the user's authority to operate this equipment.

This device complies with Part 15 of the FCC Rules. Operation is subject to the following two conditions: (1) this device may not cause harmful interference, and (2) this device must accept any interference received, including interference that may cause undesired operation.

Industry Canada Class A Emission Compliance Statement

This Class A digital apparatus meets all requirements of the Canadian Interference-Causing Equipment Regulations.

Avis de conformité aux normes d'Industrie Canada

Cet appareil numérique de la classe A respecte toutes les exigences du Règlement sur le matériel brouilleur du Canada.

European Union (EU) Mark of Conformity Statement

This product is in conformity with the protection requirements of EU Council Directive 89/336/EEC on the approximation of the laws of the Member States relating to electromagnetic compatibility. IBM cannot accept responsibility for any failure to satisfy the protection requirements resulting from a non-recommended modification of the product, including fitting of non-IBM option cards.

Properly shielded and grounded cables and connectors (IBM part number 72H4447 or equivalent for the data/fax modem) must be used in order to reduce the potential for causing interference to radio and TV communications and to other electrical or electronic equipment. IBM cannot accept responsibility for any interference caused by using other than recommended cables and connectors.

Warning: This is a Class A product. In a domestic environment this product may cause radio interference in which case the user may be required to take adequate measures.

Zulassungsbescheinigung laut dem Deutschen Gesetz über die elektromagnetische Verträglichkeit von Geräten (EMVG) vom 30. August 1995 (bzw. der EMC EG Richtlinie 89/336)

Dieses Gerät ist berechtigt in Übereinstimmung mit dem Deutschen EMVG das EG-Konformitätszeichen - CE - zu führen.

Verantwortlich für die Konformitätserklärung nach Paragraph 5 des EMVG ist die IBM Deutschland Informationssysteme GmbH, 70548 Stuttgart.

Informationen in Hinsicht EMVG Paragraph 3 Abs. (2) 2:

Das Gerät erfüllt die Schutzanforderungen nach EN 50082-1 und EN 55022 Klasse A.
--

EN 55022 Klasse A Geräte müssen mit folgendem Warnhinweis versehen werden:
"Warnung: dies ist eine Einrichtung der Klasse A. Diese Einrichtung kann im Wohnbereich Funkstörungen verursachen; in diesem Fall kann vom Betreiber verlangt werden, angemessene Maßnahmen durchzuführen und dafür aufzukommen."

EN 50082-1 Hinweis:

"Wird dieses Gerät in einer industriellen Umgebung betrieben (wie in EN 50082-2 festgelegt), dann kann es dabei eventuell gestört werden. In solch einem Fall ist der Abstand bzw. die Abschirmung zu der industriellen Störquelle zu vergrößern."

Anmerkung:

Um die Einhaltung des EMVG sicherzustellen sind die Geräte, wie in den IBM Handbüchern angegeben, zu installieren und zu betreiben.

Japanese Voluntary Control Council for Interference (VCCI) Statement

This is a Class A product based on the standard of the Voluntary Control Council for Interference by Information Technology Equipment (VCCI). If this equipment is used in a domestic environment, radio disturbance may arise. When such trouble occurs, the user may be required to take corrective actions.

この装置は、情報処理装置等電波障害自主規制協議会（VCCI）の基準に基づくクラスA情報技術装置です。この装置を家庭環境で使用すると電波妨害を引き起こすことがあります。この場合には使用者が適切な対策を講ずるよう要求されることがあります。

CISPR22 Compliance Statement

This product has been tested and found to comply with the limits for Class A Information Technology Equipment according to CISPR22 / European Standard EN 55022. The limits for Class A equipment were derived for commercial and industrial environments to provide reasonable protection against interference with licensed communication equipment.

Warning: This is a Class A product. In a domestic environment this product may cause radio interference in which case the user may be required to take adequate measures.

Trademarks

The following terms are trademarks of the International Business Corporation in the United States and/or other countries:

APPN	Nways	PowerPC
IBM	OS/2	PS/2
Library Reader		

Other company, product, and service names may be trademarks or service marks of others.

Appendix C. Safety Information



Danger: Before you begin to install this product, read the safety information in *Caution: Safety Information—Read This First*, SD21-0030. This booklet describes safe procedures for cabling and plugging in electrical equipment.



Gevaar: Voordat u begint met de installatie van dit produkt, moet u eerst de veiligheidsinstructies lezen in de brochure *PAS OP! Veiligheidsinstructies—Lees dit eerst*, SD21-0030. Hierin wordt beschreven hoe u elektrische apparatuur op een veilige manier moet bekabelen en aansluiten.



Danger: Avant de procéder à l'installation de ce produit, lisez d'abord les consignes de sécurité dans la brochure *ATTENTION: Consignes de sécurité—A lire au préalable*, SD21-0030. Cette brochure décrit les procédures pour câbler et connecter les appareils électriques en toute sécurité.



Perigo: Antes de começar a instalar este produto, leia as informações de segurança contidas em *Cuidado: Informações Sobre Segurança—Leia Isto Primeiro*, SD21-0030. Esse folheto descreve procedimentos de segurança para a instalação de cabos e conexões em equipamentos elétricos.



危險：安裝本產品之前，請先閱讀
"Caution: Safety Information—Read
This First" SD21-0030 手冊中所提
供的安全注意事項。這本手冊將會說明
使用電器設備的纜線及電源的安全程序。



Opasnost: Prije nego što počnete sa instalacijom produkta, pročitajte naputak o pravilima o sigurnom rukovanju u
Upozorenje: Pravila o sigurnom rukovanju - Prvo pročitaj ovo, SD21-0030. Ovaj privitak opisuje sigurnosne postupke za priključivanje kabela i priključivanje na električno napajanje.



Upozornění: než zahájíte instalaci tohoto produktu, přečtěte si nejprve bezpečnostní informace v pokynech „Bezpečnostní informace“ č. 21-0030. Tato brožurka popisuje bezpečnostní opatření pro kabeláž a zapojení elektrického zařízení.



Fare! Før du installerer dette produkt, skal du læse sikkerhedsforskrifterne i *NB: Sikkerhedsforskrifter—Læs dette først* SD21-0030. Vejledningen beskriver den fremgangsmåde, du skal bruge ved tilslutning af kabler og udstyr.



Gevaar Voordat u begint met het installeren van dit produkt, dient u eerst de veiligheidsrichtlijnen te lezen die zijn vermeld in de publikatie *Caution: Safety Information - Read This First*, SD21-0030. In dit boekje vindt u veilige procedures voor het aansluiten van elektrische apparatuur.



VAARA: Ennen kuin aloitat tämän tuotteen asennuksen, lue julkaisussa *Varoitus: Turvaohjeet—Lue tämä ensin*, SD21-0030, olevat turvaohjeet. Tässä kirjasessa on ohjeet siitä, miten sähkölaitteet kaapeloidaan ja kytketään turvallisesti.



Danger : Avant d'installer le présent produit, consultez le livret *Attention : Informations pour la sécurité — Lisez-moi d'abord*, SD21-0030, qui décrit les procédures à respecter pour effectuer les opérations de câblage et brancher les équipements électriques en toute sécurité.



Vorsicht: Bevor mit der Installation des Produktes begonnen wird, die Sicherheitshinweise in *Achtung: Sicherheitsinformationen—Bitte zuerst lesen*, IBM Form SD21-0030. Diese Veröffentlichung beschreibt die Sicherheitsvorkehrungen für das Verkabeln und Anschließen elektrischer Geräte.



Κίνδυνος: Πριν ξεκινήσετε την εγκατάσταση αυτού του προϊόντος, διαβάστε τις πληροφορίες ασφάλειας στο φυλλάδιο *Caution: Safety Information-Read this first*, SD21-0030. Στο φυλλάδιο αυτό περιγράφονται οι ασφαλείς διαδικασίες για την καλωδίωση των ηλεκτρικών συσκευών και τη σύνδεσή τους στην πρίζα.



Vigyázat: Mielőtt megkezdi a berendezés üzembe helyezését, olvassa el a *Caution: Safety Information— Read This First*, SD21-0030 könyvecskében leírt biztonsági információkat. Ez a könyv leírja, milyen biztonsági intézkedéseket kell megtenni az elektromos berendezés huzalozásakor illetve csatlakoztatásakor.



Pericolo: prima di iniziare l'installazione di questo prodotto, leggere le informazioni relative alla sicurezza riportate nell'opuscolo *Attenzione: Informazioni di sicurezza — Prime informazioni da leggere* in cui sono descritte le procedure per il cablaggio ed il collegamento di apparecchiature elettriche.



危険： 導入作業を開始する前に、安全に関する小冊子SD21-0030 の「最初にお読みください」(Read This First)の項をお読みください。この小冊子は、電気機器の安全な配線と接続の手順について説明しています。



위험: 이 제품을 설치하기 전에 반드시
"주의: 안전 정보-시작하기 전에"
(SD21-0030) 에 있는 안전 정보를
읽으십시오.



Fare: Før du begynner å installere dette produktet, må du lese sikkerhetsinformasjonen i *Advarsel: Sikkerhetsinformasjon — Les dette først*, SD21-0030 som beskriver sikkerhetsrutinene for kabling og tilkobling av elektrisk utstyr.



Uwaga:
Przed rozpoczęciem instalacji produktu należy zapoznać się z instrukcją:
"Caution: Safety Information - Read This First", SD21-0030.
Zawiera ona warunki bezpieczeństwa przy podłączaniu do sieci elektrycznej
i eksploatacji.



Perigo: Antes de iniciar a instalação deste produto, leia as informações de segurança *Cuidado: Informações de Segurança — Leia Primeiro*, SD21-0030. Este documento descreve como efectuar, de um modo seguro, as ligações eléctricas dos equipamentos.



ОСТОРОЖНО: Прежде чем устанавливать этот продукт, прочтите Инструкцию по технике безопасности в документе "Внимание: Инструкция по технике безопасности -- Прочсть в первую очередь", SD21-0030. В этой брошюре описаны безопасные способы кабирования и подключения электрического оборудования.



Nebezpečnostvo: Pred inštaláciou výrobku si prečítajte bezpečnosté predpisy v
Výstraha: Bezpečnosté predpisy - Prečítaj ako prvé,
SD21 0030. V tejto brožúrke sú opísané bezpečnosté postupy pre pripojenie elektrických zariadení.



Pozor: Preden začnete z instalacijo tega produkta preberite poglavje: "Opozorilo: Informacije o varnem rokovanju-preberi pred uporabo," SD21-0030. To poglavje opisuje pravilne postopke za kabliranje,



Peligro: Antes de empezar a instalar este producto, lea la información de seguridad en *Atención: Información de Seguridad — Lea Esto Primero*, SD21-0030. Este documento describe los procedimientos de seguridad para cablear y enchufar equipos eléctricos.



Varning — livsfara: Innan du börjar installera den här produkten bör du läsa säkerhetsinformationen i dokumentet *Varning: Säkerhetsföreskrifter— Läs detta först*, SD21-0030. Där beskrivs hur du på ett säkert sätt ansluter elektrisk utrustning.



危險：

開始安裝此產品之前，請先閱讀安全資訊。

注意：

請先閱讀 - 安全資訊 SD21-0030

此冊子說明插接電器設備之電纜線的安全程序。

Index

A

- A-MSS Server Module
 - accessing
 - in-band 3-1
 - out-of-band 3-1
 - documentation 1-1
 - hardware 1-1
 - installation 1-1
 - problem solving 2-1
 - setup 4-3
- accessing the A-MSS Server Module
 - in-band 3-1
 - out-of-band 3-1
 - overview 3-1
 - physical connection 3-4
 - remote connection 3-4
- address
 - ATM 4-4
 - Ethernet 3-4, 4-4
 - SLIP 3-3
- asynchronous transport protocol
 - See ATM (asynchronous transport protocol)
- ATM (asynchronous transport protocol)
 - address 4-4
- ATM backplane
 - connect 1-3
 - enable 1-3

B

- backing up the configuration 4-5
- bridging
 - configuring, general 4-3
 - configuring, Quick Configuration 4-4

C

- CD-ROM
 - installation vii
 - Library Reader vii
 - MSS Server publications vii
- CD-ROM publications vii
- changes since last edition viii
- command line interface (a configuration method) 4-5
- common tasks A-1
- community name 4-5
- configuration
 - backup 4-5
 - full
 - managing problems 4-6
 - setting up the A-MSS Server Module 4-5
 - initial
 - problems 4-5

- configuration (*continued*)
 - initial (*continued*)
 - setting up the A-MSS Server Module 4-3
 - IP 4-4
 - IPX 4-4
 - overview v
 - problems 4-5
 - SLIP 3-3
- Configuration Program (a configuration method) 4-5
- connecting to the MSS Server 3-1
- console access
 - local 3-2
 - remote 3-2

D

- default configuration 1-4, 4-1
- default settings
 - Data/Fax PCMCIA Modem 3-3
 - MSS Server 4-1
 - serial port 3-3

E

- Ethernet
 - 10BASE-T cable 3-4
 - address 3-4, 4-4

F

- fax, default settings 3-3

H

- hardware, methods of connection 3-1

I

- in-band access 3-1
- installation
 - A-MSS Server Module 1-1
 - CD-ROM vii
 - overview v
 - PCMCIA device 1-1
- IP (Internet Protocol), configuring 4-4
- IPX (Internet Package Exchange), configuring 4-4

L

- LAN emulation
 - configuring 4-4
 - default configuration 4-1

LEDs
 link 1-4
 module status 1-4
 OK 1-4
 port activity 1-4
 port status 1-4
 reset 1-4
 traffic 1-4
 warning 1-4
light emitting diodes
 See LEDs
link LED 1-4
local connection 3-1, 3-2

M

managing configuration problems 4-5
methods of connection 3-1
 ATM network 3-4
 SLIP 3-3
 TTY 3-1
modem 3-3
module status LED 1-4
MSS Server library vi

O

OK LED 1-4
OPCON (Operator Console program) 4-5
out-of-band access 3-1

P

parameters, default configuration 4-1
PCMCIA modem 3-3
physical access to A-MSS Server Module 3-4
port activity LED 1-4
port status LED 1-4
port, default settings 3-3
problem solving 2-1
problems
 configuration 4-5
 LEDs 1-4, 2-1
protocol
 configuration 4-4
 Quick Configuration 4-4
publications
 CD-ROM vii
 hardcopy vii
 Library Reader vii
 softcopy vii

Q

Quick configuration
 bridging 4-4
 IP 4-4

Quick configuration (*continued*)
 IPX 4-4
 protocol configuration 4-4

R

remote connection 3-1, 3-2, 3-4
reset LED 1-4
restart A-MSS Server Module 4-3, 4-5

S

safety information C-1
setup
 A-MSS Server Module 4-3
 configuration 4-3
SLIP
 addresses 3-3
 configuration 3-3
SNMP
 community name 4-5
 initial configuration 4-5

T

traffic LED 1-4
TTY (teletype) connection 3-1

W

Web Browser (a configuration method) 4-5
web sites for MSS Server information viii
wrong slot LED 1-4

Tell Us What You Think!

Multiprotocol Switched Services (MSS) Server Module Installation and Initial Configuration Guide

Publication No. GA27-4141-01

We hope you find this publication useful, readable, and technically accurate, but only you can tell us! Your comments and suggestions will help us improve our technical publications. Please take a few minutes to let us know what you think by completing this form. If you are in the U.S.A., you can mail this form postage free or fax it to us at 1-800-253-3520. Elsewhere, your local IBM branch office or representative will forward your comments or you may mail them directly to us.

Overall, how satisfied are you with the information in this book?	Satisfied	Dissatisfied
	<input type="checkbox"/>	<input type="checkbox"/>

How satisfied are you that the information in this book is:	Satisfied	Dissatisfied
Accurate	<input type="checkbox"/>	<input type="checkbox"/>
Complete	<input type="checkbox"/>	<input type="checkbox"/>
Easy to find	<input type="checkbox"/>	<input type="checkbox"/>
Easy to understand	<input type="checkbox"/>	<input type="checkbox"/>
Well organized	<input type="checkbox"/>	<input type="checkbox"/>
Applicable to your task	<input type="checkbox"/>	<input type="checkbox"/>

Specific comments or problems:

Please tell us how we can improve this book:

Thank you for your comments. If you would like a reply, provide the necessary information below.

Name

Address

Company or Organization

Phone No.



Fold and Tape

Please do not staple

Fold and Tape

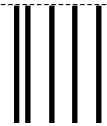

NO POSTAGE
NECESSARY
IF MAILED IN THE
UNITED STATES

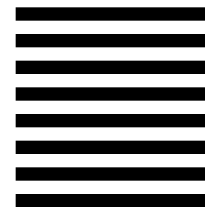

BUSINESS REPLY MAIL

FIRST-CLASS MAIL PERMIT NO. 40 ARMONK, NEW YORK

POSTAGE WILL BE PAID BY ADDRESSEE

Design & Information Development
Dept. CGF/Bldg. 656
International Business Machines Corporation
PO BOX 12195
RESEARCH TRIANGLE PARK NC 27709-9990



Fold and Tape

Please do not staple

Fold and Tape



Part Number: 86H2917



Printed in the United States of America
on recycled paper containing 10%
recovered post-consumer fiber.

GA27-4141-01



86H2917

